

Portfolio

Food & Beverage



Dear reader,

The demand for consistent product quality and taste poses major challenges for the Food & Beverage industry. Food safety is more than an obligation. It is crucial to the brand and profitability of every food producer.

Food and beverage products must meet specific requirements. For this reason, food producers must follow hygiene regulations and standards to ensure food safety and reliability while maintaining efficiency.

Endress+Hauser is a complete provider for the Food & Beverage industry. Our full range of instruments, tailor-made solutions and services meet global hygiene regulations and ensure consistent product quality and plant availability, while conserving resources and lowering costs.

Our brochure presents a visual overview of the most relevant processes in food and beverage production and helps you choose the instruments that best fit your needs.

Endress+Hauser is your trusted partner for all measurement tasks. In-depth application know-how, extensive experience and a global presence are what set us apart. This allows you to adapt optimally to every challenge and environment.

Ensuring your success is our mission.



Learn more about our digitalization know-how
Page 28



Discover our customers' experiences.
Page 46



Want to know more about Food & Beverage?
www.endress.com/food-beverage

6 All from one source

Benefit from our encompassing portfolio of products, solutions and services throughout the whole lifecycle of your plant.



8 Dairy process

Ensure high quality dairy processing with accurate process control.



46 References

Strong collaboration with our customers. Read some of their thoughts on our offering.



Table of contents

All from one source

6 All from one source

Dairy

8 Dairy process
10 Milk intake
12 Milk heating and pasteurization
14 Milk standardization and homogenization

Brewery

16 Brewhouse
18 Beer mashing and lautering
20 Fermentation

Service

22 Service by your side

Softdrinks

24 Syrup preparation and mixing

Juice

26 Juice concentrate intake and mixing

Digitalization/IIoT

28 How sweet is the taste of digitalization?

Sugar

30 Sugar production
32 Evaporation
34 Crystallization

Solutions

36 Solutions

Edible Oil

38 Edible oil refining
40 Oil bleaching
42 Oil deodorization

CIP

44 Cleaning in Place – CIP process

References

46 Customer insights

i Industry requirements

Endress+Hauser's entire hygienic product offering fulfills the food and beverage industry's requirements.

- Meet 3-A sanitary standards and assessed according to test procedure of EHEDG
- Food contact material compliant with FDA "GRAS", EC 1935/2004 and China GB4806

Edible Oil



Dairy



Beer



Sugar





SUPERMARKET

Soft
Drinks



All from one source

Benefit from our extensive portfolio of products, solutions and services throughout your plant's entire life cycle

Expectations and demands are growing. Be it shrinking budgets or shorter timelines, your job is becoming more demanding than ever. To meet your goals, you need a partner that simplifies your life instead of making it more complicated.

That's why you can rely on Endress+Hauser, because when it comes to instrumentation, we are the only primary supplier capable of covering all critical parameters in food and beverage manufacturing.

How does this help you? Simple. It starts with the selection and ordering process. There is no need to contact multiple suppliers and valuable time is saved during the entire order process. You have only one point of contact right from the start. In addition, we not only offer multiple parameters, but also multiple technologies for your measuring tasks. That means our experienced technicians can recommend the optimal solution for your applications.

Take flow measurement for example. For some tasks, magnetic inductive flowmeters are the ideal technology. For others, the Coriolis principle is more advantageous. When thinking about commissioning, having instruments from only one supplier results in a smoother overall process. And to be sure that all of the bases are covered, our experienced service technicians can even install and commission instruments from a wide range of suppliers. After your plant or application is up and running, you can still benefit from relying on a primary instrumentation vendor like Endress+Hauser. Thanks to our modular instrumentation platform, you can reduce the number of spare parts you need to keep in stock. And services like maintenance, verification and calibration are also easier to manage if you rely on a single provider.





Why different measuring technologies matter

They are many voices in our industry that like to talk about one measuring technology only and they recommend it for every application. At Endress+Hauser we take a different approach. We know that every measuring technology has its advantages and disadvantages. That's why it is so important to take a closer look at the application and find the optimal technology. For level measurements as an example, radar and ultrasound technologies are available. While ultrasound works best for shorter distances in small, confined spaces, radar works best at longer distances and in demanding applications. In addition, radar is not influenced by dust or foam. Our technicians support you in defining the right technology for your applications based on their experience and industry knowledge.



Dairy process

Ensure high quality dairy processing with accurate process control

Dairy production is a business with tight margins and high-quality expectations. Processes can be optimized for cost control while keeping the product quality at a consistently high level.

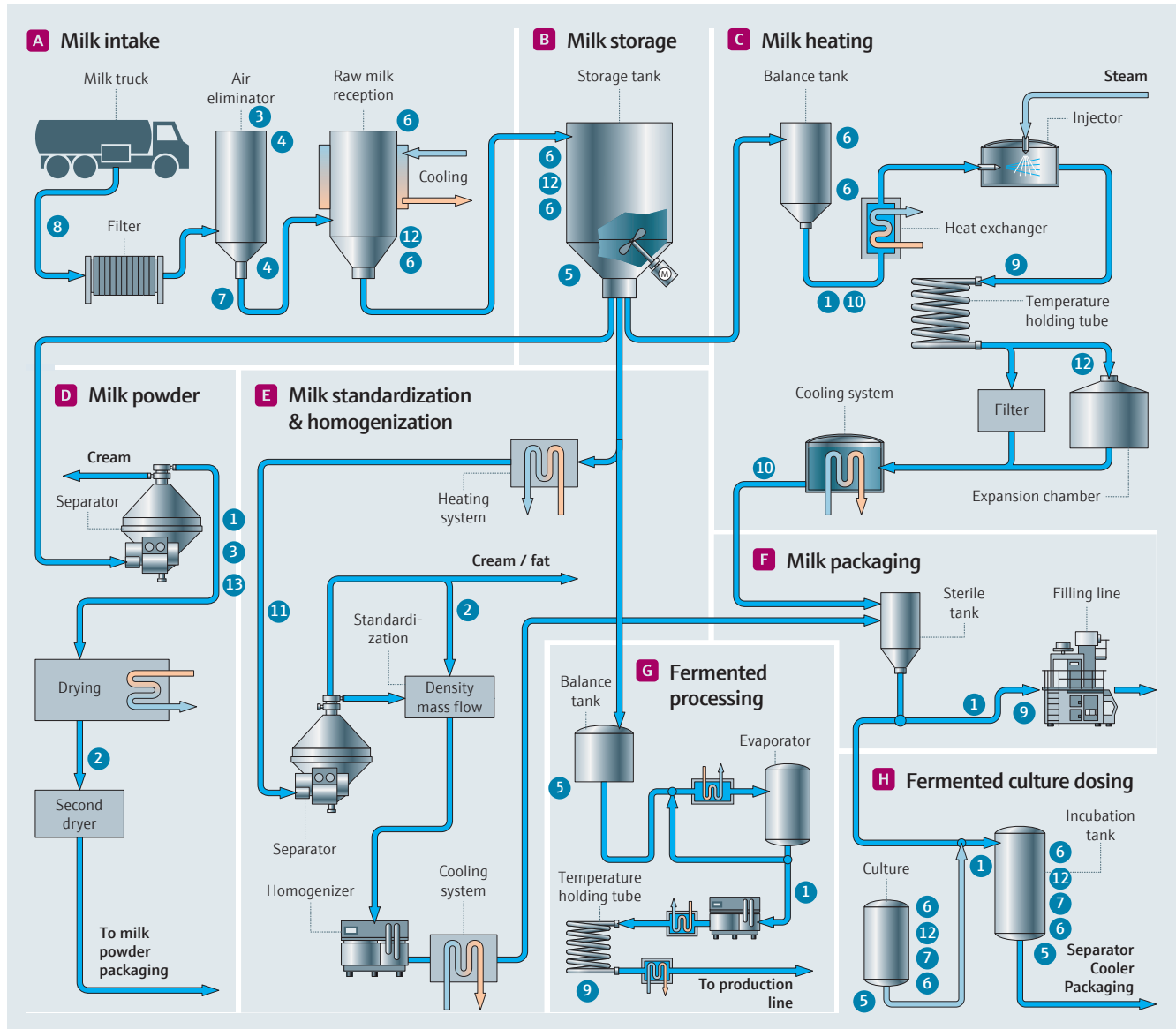

Flow

Flow in powder process, fermented processing, fermented culture dosing, filling line

1 Proline Promag H 100

Flow in drying, standardization

2 Proline Promass F 100

Level

Level control in air eliminator

3 Liquicap FMI51

Point level control in air eliminator, evaporator

4 Liquiphant FTL50H

Level control in raw milk storage, fermented processing, fermented culture dosing, sterile tank

5 Deltapilot FMB50

Point level control raw milk reception, milk storage tank, balance tank, evaporator, fermented culture dosing, pump dry-run protection

6 Liquiphant FTL33

Liquid analysis

pH control in milk intake, fermented processing, fermented culture dosing

7 Memosens CPS77E

Conductivity control for product identification

8 Smartec CLD134

Buildup monitoring in filling line, holding tube, storage tank

9 Liquitrend QMW43

Pressure

Pressure in chiller loop supply, evaporator

10 Cerabar PMP51B

Pressure in powder process, fermented processing, fermented culture dosing

11 Cerabar PMP23

Temperature

Temperature in raw milk tank, heat exchanger, powder process, fermented processing, fermented culture dosing, sterile tank

12 iTHERM TM411

Temperature in chiller loop return, heat exchanger, fermented processing

13 iTHERM TM401

Milk intake

Ensuring highest quality and accurate quantity

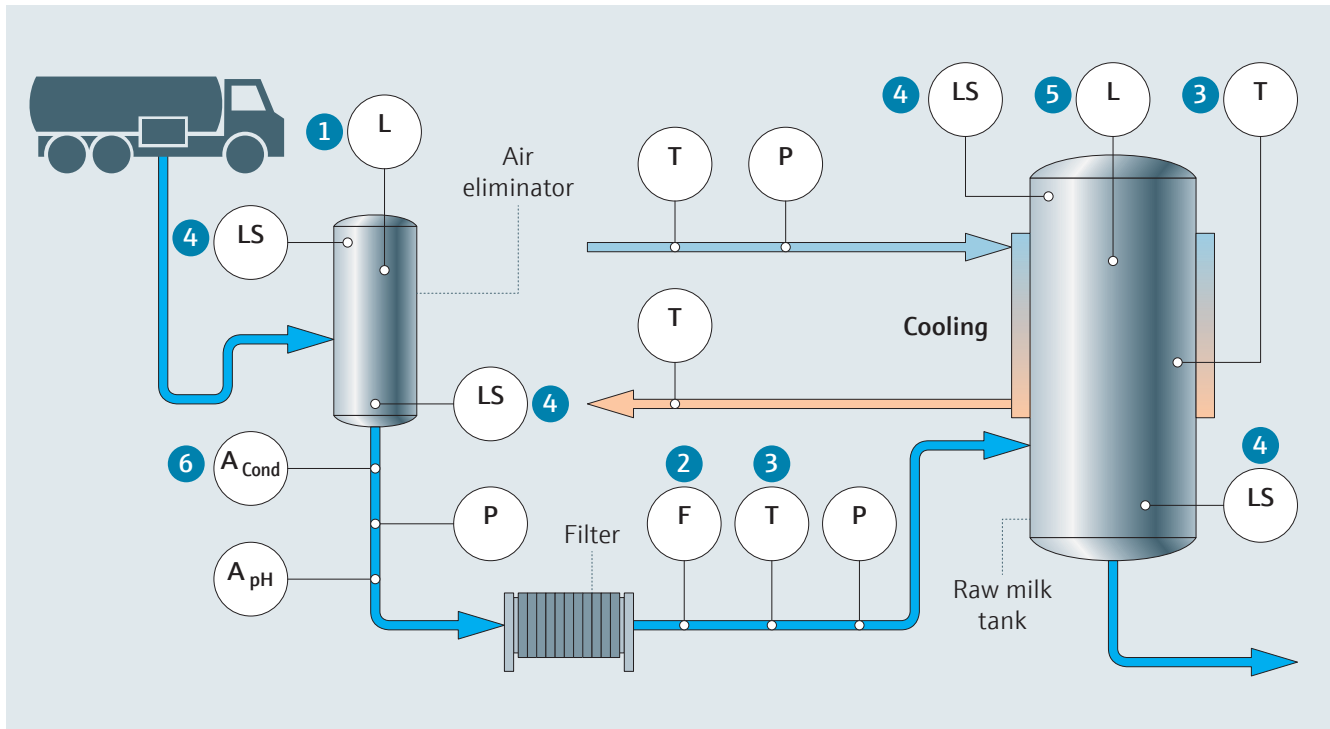

1 – Liquicap FMI51

Capacitance probe for fast and reliable continuous level measurements

- Plug and play device, no need for calibration (factory pre-configuration)
- Not affected by foam and turbulences



www.endress.com/fmi51



2 – Proline Promass Q 300

Coriolis flowmeter for stable measurement of milk with entrained air and for reliable mass balancing

- Direct mass flow measurement
- Optimized measuring performance for fluids with entrained gas thanks to unique Multi Frequency Technology (MFT)
- Available with custody transfer approvals



www.endress.com/promass-q300



3 – iTHERM TM311

Pt100 compact thermometer, with optional integrated IO-Link and 4-20 mA transmitter, programmable via PC

- Fast installation and easy commissioning
- Excellent metrological properties thanks to innovative sensor technology
- Reliable operation ensured by approvals and certificates



www.endress.com/tm311



4 – Liquipoint FTW23

Cost effective point level switch for water-based liquids

- Easy installation thanks to compact design, even in confined spaces or with restricted access
- CIP and SIP cleanability ensured - up to protection class IP69
- Plug-and-play device without the need for medium adjustment
- LED indication for on-site function check
- IO-Link functionality reduces costs and complexity due to easy configuration and operation (optional)



www.endress.com/ftw23



5 – Deltapilot FMB50

Compact pressure sensor with Contite measuring cell for hydrostatic level measurements

- Hermetically-sealed Contite measuring cell with full condensate-resistance and minimum temperature effects
- High reference accuracy for precise hydrostatic level measurements
- Seamless and independent system integration with HART, IO-Link, Profibus, etc.



www.endress.com/fmb50



6 – Smartec CLD134

Reliable conductivity measurements for product identification in the milk intake process

- Conductivity measurements for raw milk or cream
- Unique hygienic design prevents recontamination
- Increased product yield thanks to advanced functionalities like remote parameter set change



www.endress.com/cld134

Milk heating and pasteurization

Guaranteed milk safety and shelf life extension

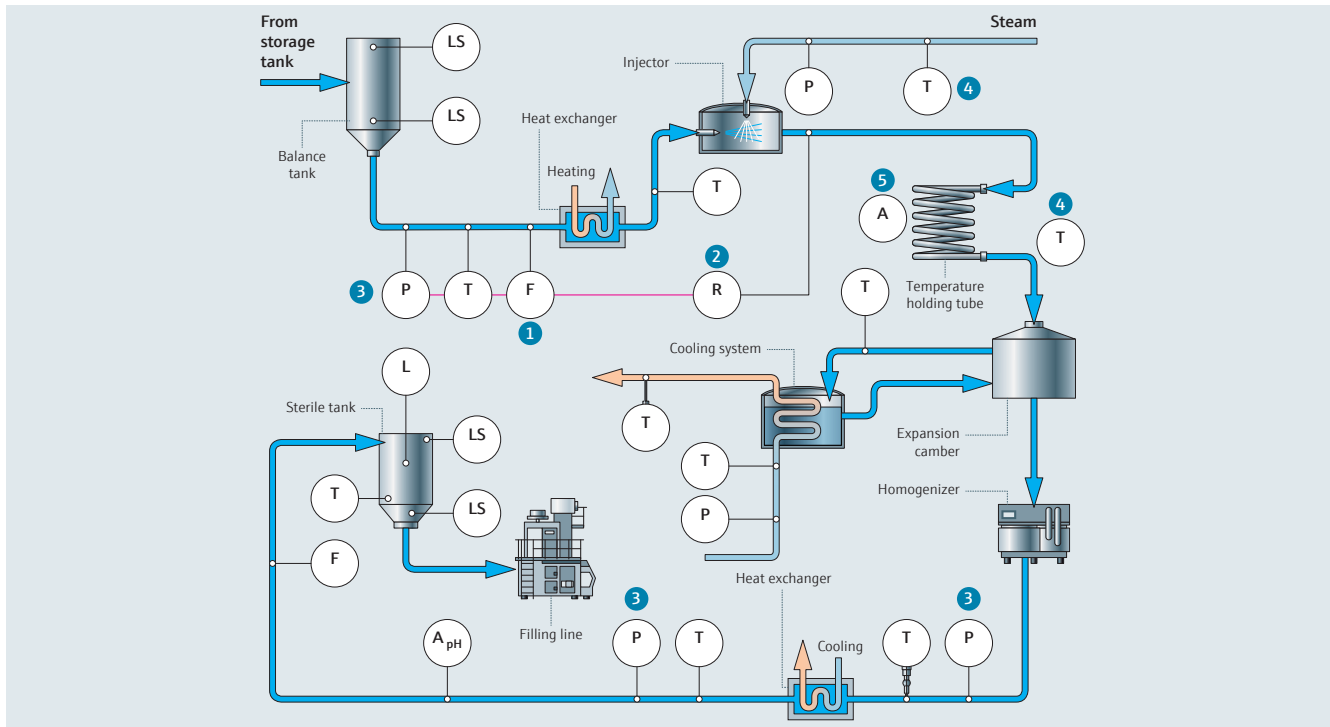

1 – Proline Promag H 100

The proven flow specialist for the food and beverage industry

- Fewer measuring points thanks to multivariable measurement of volume flow, temperature and conductivity
- Energy-saving measurements – no pressure loss due to full-bore design
- Heartbeat Technology for device verification without process interruption



www.endress.com/promag-h100



2 – Memograph M RSG45

Advanced Data Manager: stores, visualizes, analyzes and communicates

- Stainless steel front with touch-screen operation
- Plant and apparatus engineering and construction, e.g. milk pasteurization plants
- Batch analysis
- High degree of data security



www.endress.com/rsg45





3 – Cerabar PMP23

Compact and cost-effective hygienic pressure transducer

- Fully welded design maximizes process safety by minimizing the use of gaskets
- IP69 ingress protection for heavy washdown conditions
- IO-Link functionality reduces costs and complexity due to easy configuration and operation (optional)

 www.endress.com/pmp23
measurements



4 – iTHERM TrustSens TM371

Hygienic compact RTD thermometer: 100% compliance, 0% effort

- Risk and cost reduction thanks to self-calibration and Heartbeat Technology
- Automated documentation and storage of 350 calibration points
- Elimination of non-conformities or undetected failures

 www.endress.com/tm371



5 – Liquitrend QMW43

Compact multiparameter sensor for continuous buildup measurements

- Reliable measurement of buildup thickness regardless of media type
- Verification of cleaning status, no need to open tanks, pipes or heat exchangers
- Compact and flush-mounted stainless-steel sensor with minimal process immersion
- Digital communication via IO-Link (optional)

 www.endress.com/qmw43

Milk standardization and homogenization

Adjust cream content and ensure consistent distribution

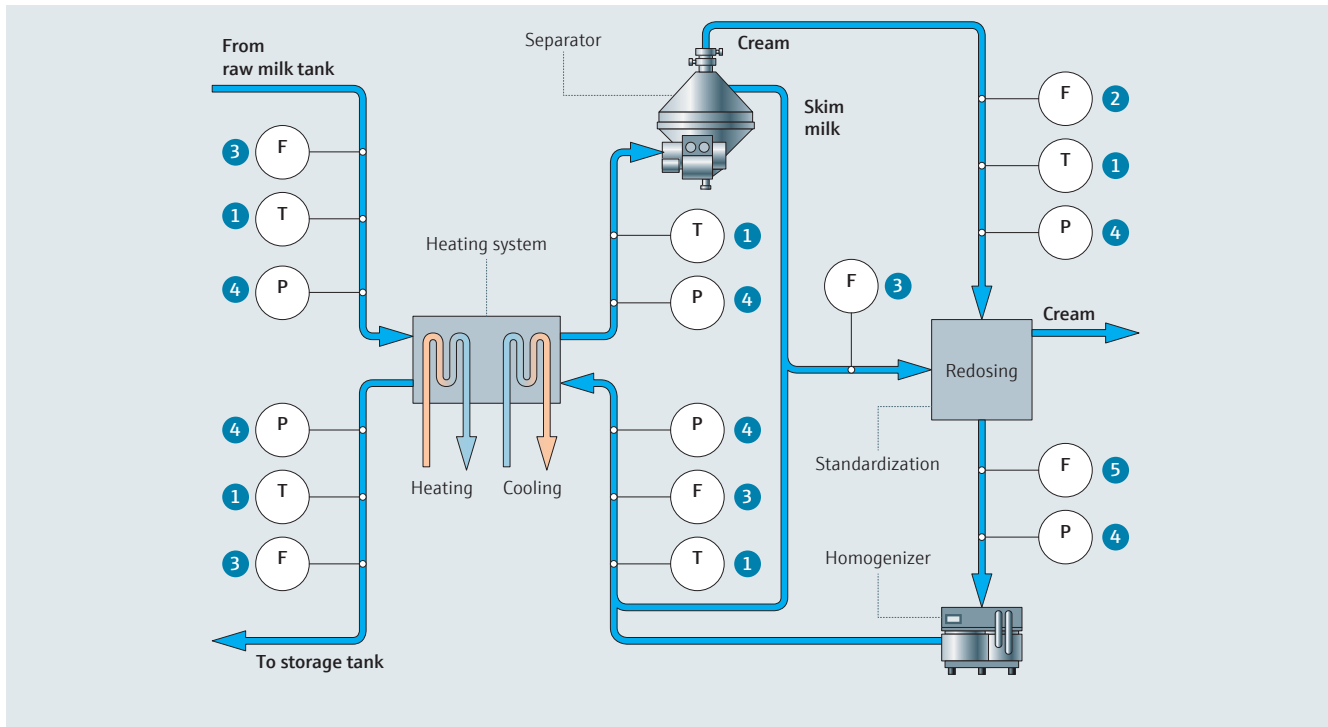

1 – iTHERM TM311

Pt100 compact thermometer, with optional integrated IO-Link and 4–20 mA transmitter, programmable via PC

- Fast installation and easy commissioning
- Excellent metrological properties thanks to innovative sensor technology
- Reliable operation ensured by approvals and certificates



www.endress.com/tm311



2 – Proline Promass Q 300

Coriolis flowmeter for unmatched mass flow and density measuring accuracy even in demanding applications

- Optimal and reliable in-line product quality control
- Consistent and reliable measuring results even when the viscous fluid contains entrained air
- Multivariable measurement of density and volume flow
- Easy to clean



www.endress.com/promass-q300



3 – Proline Promag H 100

The proven flow specialist for the food and beverage industry

- Fewer measuring points thanks to multivariable measurements of volume flow, temperature and conductivity
- Energy-saving measurement – no pressure loss due to full-bore design
- Heartbeat Technology for device verification without process interruption



www.endress.com/promag-h100



4 – Cerabar PMP23

Compact and cost-effective hygienic pressure transducer

- Fully welded design maximizes process safety by minimizing the use of gaskets
- IP69 ingress protection for heavy washdown conditions
- IO-Link functionality reduces costs and complexity due to easy configuration and operation (optional)



www.endress.com/pmp23



5 – Proline Promass F 100

Robust Coriolis flowmeter with superior flow and density measuring accuracy

- Reliable, robust sensor: proven in hundreds of thousands of applications
- Less downtime: immediate availability after CIP/SIP cleaning
- Flexible mounting: no inlet and outlet runs required



www.endress.com/promass-f100

Brewhouse

All beer manufacturing processes must be designed to ensure consistently high product quality

Beer is brewed using naturally grown products that vary from year to year and from harvest to harvest. The brewer must react to these changes to produce a beer of stable quality, and moreover, the beer must taste the same year after year in order to meet the customer's expectations.

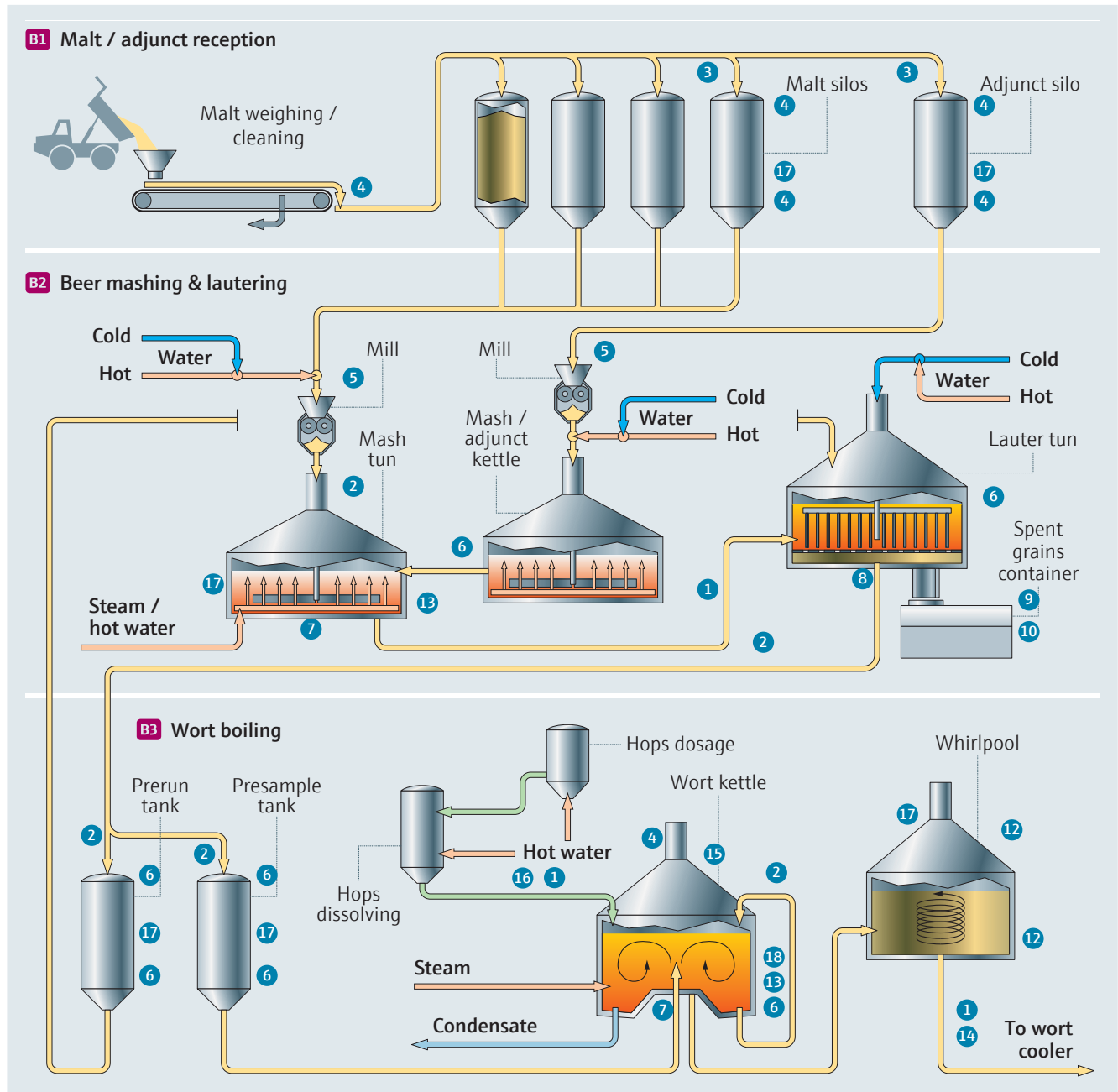

Flow

Flow in measurement hops dosing, wort to cellar	1 Proline Promag H 100
Density measurement for boiling control	2 Proline Promass F 100

Level

Level control in grain silos, adjunct silo	3 Levelflex FMP56
Point level control in malt silos, adjunct silo, mash tun	4 Soliphant FTM50
Level control in mills	5 Micropilot FMR10
Point level control in lauter tun, wort kettle, prerun tank, presample tank, pump-dry protection	6 Liquiphant FTL33
Level control in mash tun, lauter tun low point level, wort kettle level control	7 Cerabar PMC51B
Lauter tun continuous level	8 Deltapilot FMB50
Spent grain continuous level	9 Micropilot FMR20
Spent grains high level switch	10 Soliphant FTM20
Wort kettle boil over detection	11 Liquicap FTI51
Whirlpool point level control	12 Liquipoint FTW33

Liquid analysis

Wort kettle pH measurement	13 Memosens CPS71E
Whirlpool color measurement	14 Color sensor OUSAF22

Pressure

Wort kettle pressure	15 Cerabar PMP51
Pressure hops dosing line	16 Cerabar PMP23

Temperature

Temperature in grain silos, adjunct silo, whirlpool, mash tun, prerun tank, presample tank	17 iTHERM TM411
Wort kettle temperature	18 iTHERM TrustSens TM371

Beer mashing and lautering

Optimize mash and quality of wort

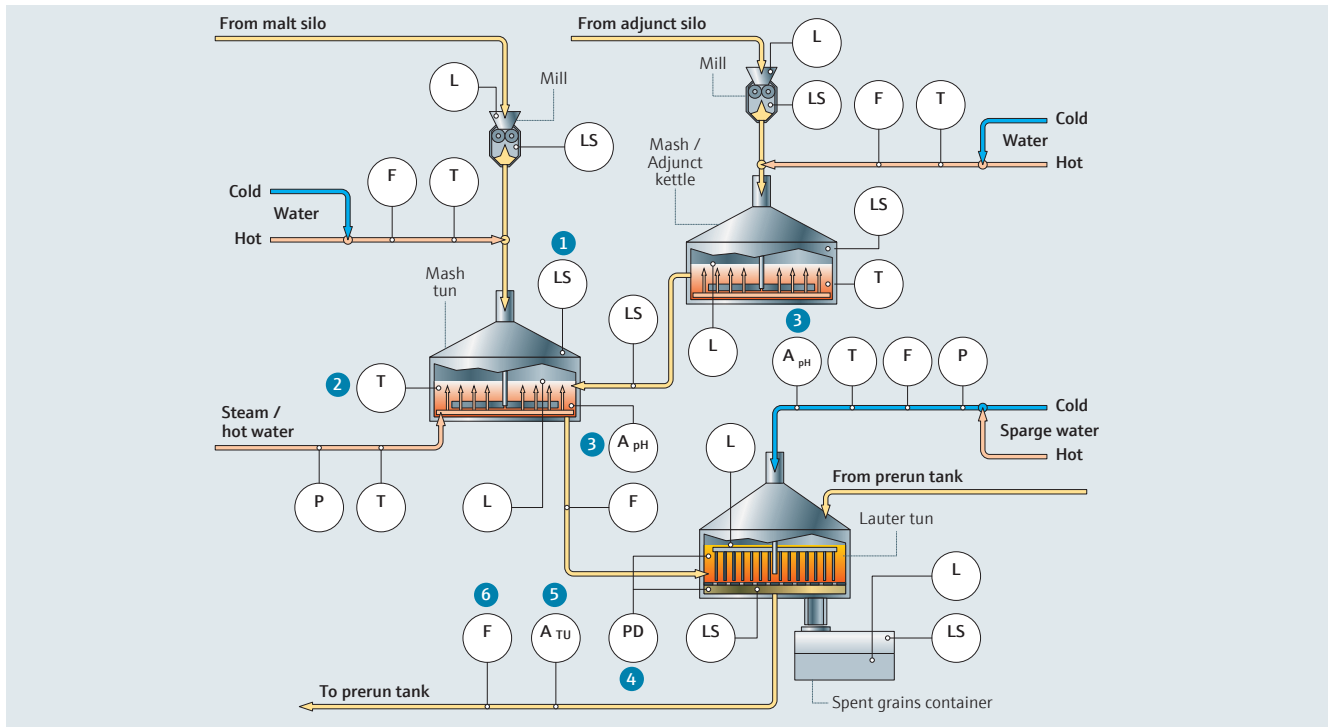

1 – Liquiphant FTL50H

Modular vibronic point level device for hygienic applications in all liquids

- Reliable function unaffected by conductivity, buildup, turbulence, foam or changing media
- Mechanically robust due to seamless sensor construction made of stainless steel and no moving parts
- Plug-and-play device, no need for calibration or adjustment



www.endress.com/ftl50h



2 – iTHERM TM411

Innovative advanced, modular RTD thermometer

- iTHERM QuickSens: fastest response times ($t_{90} = 1.5$ s) for optimal process control
- iTHERM QuickNeck – cost and time savings thanks to simple, tool-free recalibration



www.endress.com/tm411



3 – Memosens CPS61E

pH measurements in sparge water

- The sensor's exceptional accuracy and reproducibility help you keep the pH value in the optimal range for maximum product yield
- Optimal performance even at high temperatures
- Pressurized version for sugar solutions to avoid blocking of the reference
- Reduced operating costs thanks to minimized process downtime and extended sensor lifetime



www.endress.com/cps61e



4 – Deltabar FMD71

Electronic differential pressure system utilizing two robust ceramic sensor modules

- Abrasion and corrosion resistant sensors
- Fully vacuum resistant
- Superior precision for accurate level measurements
- Oil free sensor technology



www.endress.com/fmd71



5 – Inline turbidity sensor OUSTF10

Optical turbidity measurements in the supply line

- Measurement with forward scattered light according to Mebak guidelines
- Accurate and highly sensitive turbidity measurements for better product quality
- Low-maintenance sensor with long service life and stable operation
- Suitable for cleaning-in-place (CIP) and sterilization-in-place (SIP)



www.endress.com/oustf10



6 – Proline Promass E 300

Cost-efficient flowmeter with special concentration measuring functions

- Reliable, robust sensor: proven in hundreds of thousands of applications
- Less downtime: immediate availability after CIP/SIP cleaning
- Flexible mounting: no inlet and outlet runs required



www.endress.com/promass-e300

Fermentation

Ensure consistent quality batch after batch

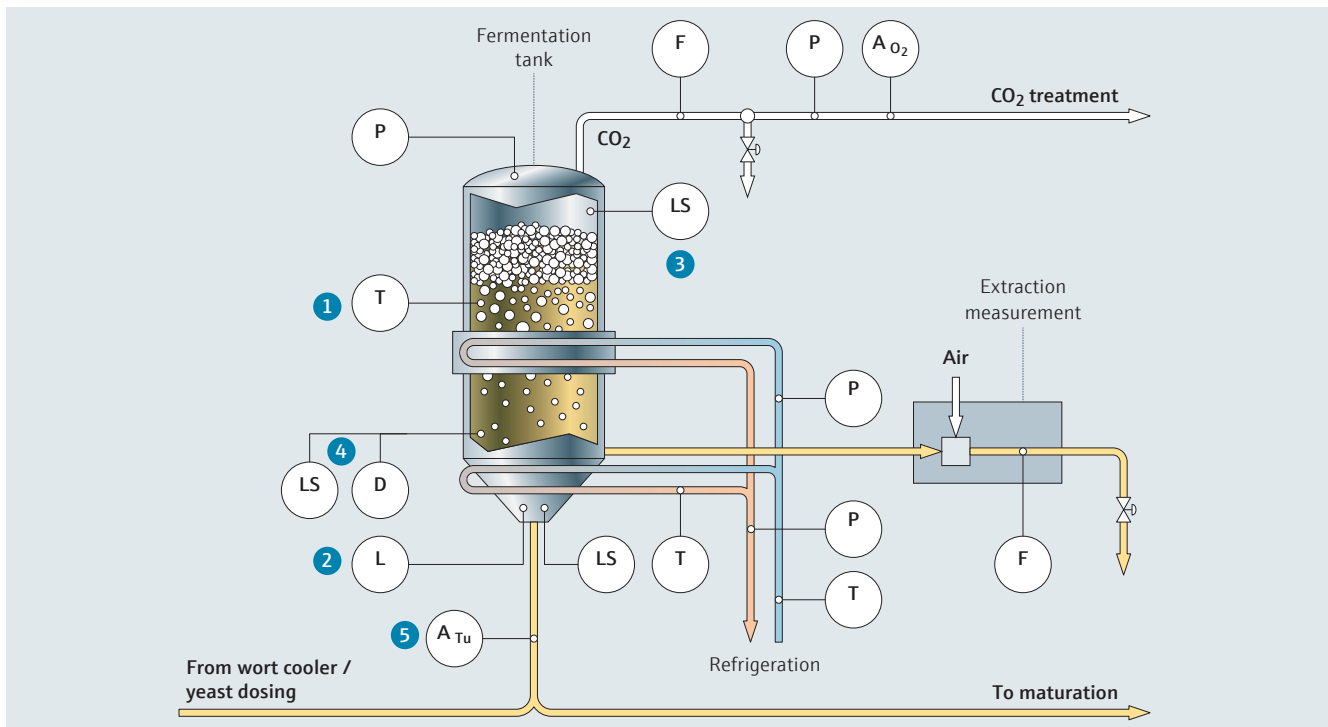

1 – iTHERM TM411

Innovative advanced, modular RTD thermometer

- iTHERM QuickSens: fastest response times ($t_{90} = 1.5$ s) for optimal process control
- iTHERM QuickNeck – cost and time savings thanks to simple, tool-free recalibration
- International hygienic certifications and approvals



www.endress.com/tm411



2 – Deltapilot FMB50

Compact pressure sensor with Contite measuring cell for hydrostatic level measurements

- Hermetically sealed Contite measuring cell with full condensate-resistance and minimum temperature effects
- High reference accuracy for precise hydrostatic level measurements
- Seamless and independent system integration with HART, IO-Link, Profibus, etc.



www.endress.com/fmb50



3 – One rod probe 11371

Point level detection of foams and conductive liquids

- Reliable on-rod probe with hygienic process connections
- Fast response times
- Variable insertion lengths
- For use with FTW325 transmitter



www.endress.com/11371

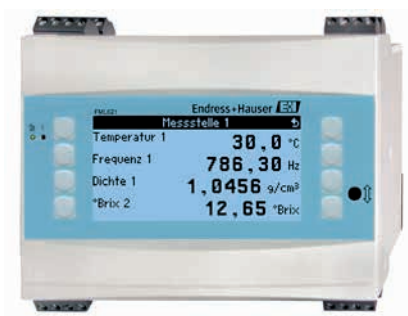

4 – Density computer FML621

Density and concentration measurements in tanks and pipes using vibration-based sensors

- Accurate and reliable density measurements
- Algorithms and tables for calculating different concentrations (e.g. °Plato, °Brix, etc.)
- Up to 8 individual measuring points connected to one mathematic module
- Use in combination with Liquiphant FTL5x / FTL6x with density electronics



www.endress.com/fml621



5 – Suspended solids and color sensor OUSAF12

Turbidity measurements for phase separation after fermentation tank

- Fast and accurate detection of phase separation between yeast and beer
- Reliable measurement values even with changing types of beer
- Use of the EasyCal system for verification of the turbidity measurement (optional)
- Suitable for cleaning-in-place (CIP) and sterilization-in-place (SIP)



www.endress.com/ousaf12



Service by your side

Our service portfolio was developed to ensure repeatability, improve plant availability, support resource conservation and guarantee food safety

By your side, with total commitment, today and into the future, Endress+Hauser will help you both meet and surpass your specific industry challenges. It is what drives us; it is what defines us. As the global 24/7 economy in which you compete brings unprecedented margin pressures, we deliver the incremental OPEX reductions and plant availability gains to make the difference.

As new regulations to protect people and the environment force industry to rethink its processes, we help you comply while remaining competitive. Moreover, we are here to ensure that relentless technological progress does not become a threat but an opportunity. With Endress+Hauser Services, you give yourself every chance of success.

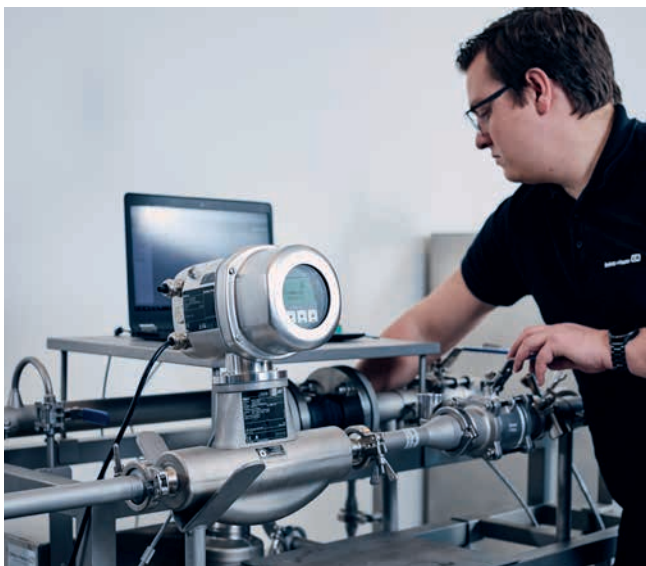

Calibration services

From on-site to fully accredited laboratory calibration, Endress+Hauser provides timely, traceable, and cost-effective calibration services to ensure both high performance and compliance of your quality critical instruments.

- Optimize calibration intervals to balance costs and risks
- Rely on Endress+Hauser calibration competence available anywhere in the world
- Benefit from ISO 17025 accreditation available for many parameters in many regions
- Continuously improve your calibration process and activities with expert insights

Maintenance and calibration optimization

How can you find the right balance between costs and maintenance activities without compromising safety? A review and redesign of the maintenance processes in a plant can help maintenance and plant managers to decide how to reach strategic asset management goals. On one hand, Endress+Hauser consultants use in-depth metrological expertise and analyze calibration data to help customers find their optimal calibration intervals. On the other hand, our asset management specialists review current maintenance processes to provide recommendations to reduce operational costs.



Support services

The global Endress+Hauser support network of technical experts is on call to guide and to support you remotely with diagnostics and troubleshooting as well as with proactive alerts to optimize your plant's availability and performance, reduce outages, and minimize disruption.

- Customize a service agreement according to your requirements
- Rely on guaranteed support availability and response times
- Obtain guided service operations, remote diagnostic and troubleshooting support from dedicated experts
- Receive proactive alerts thanks to remote health monitoring of your installed base

Syrup preparation and mixing

Precise dosing of ingredients

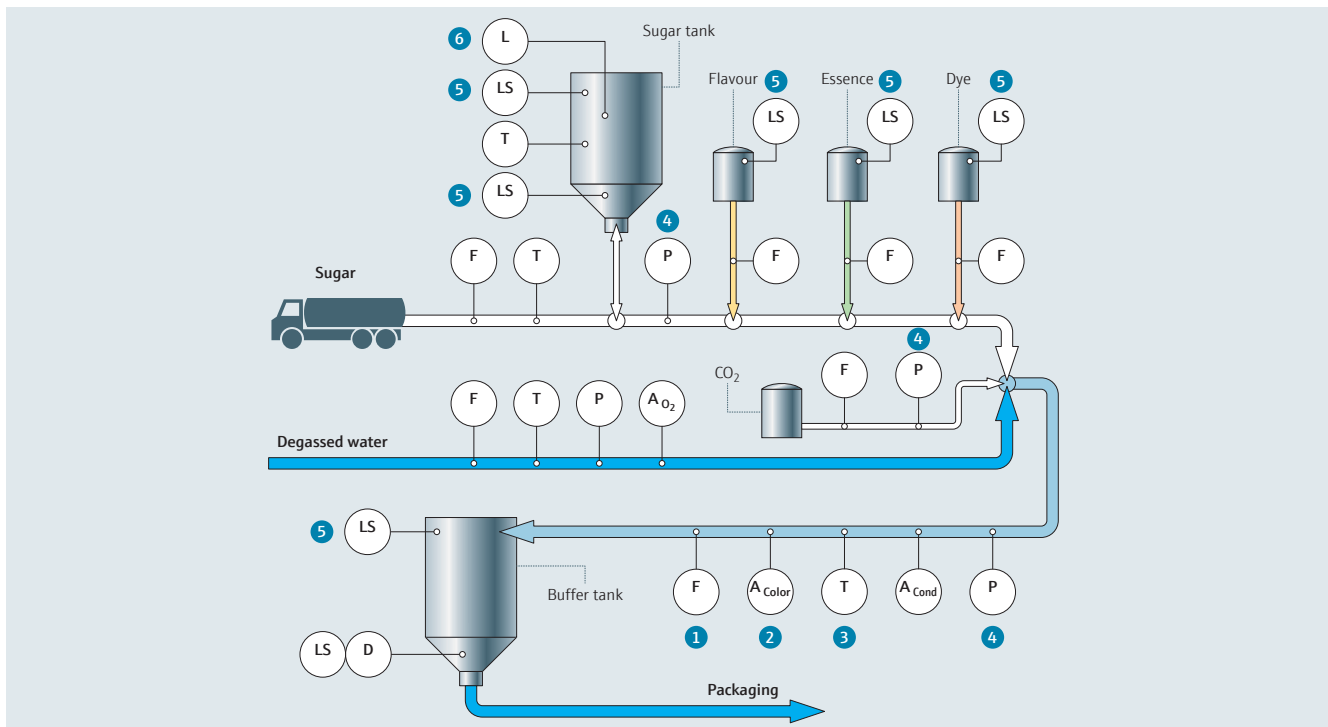

1 – Proline Promass Q300

Coriolis flowmeter for highly accurate sugar content/density measurements of beverages



- Easy cleaning - immediate availability after CIP/SIP cleaning
- Optimized for liquids with entrained gas bubbles
- Unrivalled Brix-measurements in real-time to ensure optimal product quality under real process conditions

 www.endress.com/promass-q300

2 – Color sensor OUSAF22

Color measurements for outstanding and consistent product quality



- Accurate color measurements (e.g. ICUMSA) and purity monitoring to ensure product quality
- Fast and direct inline measurement avoids expensive sampling and laboratory measurements
- Outstanding filter performance provides superior linearity
- EasyCal system for verification of the color measurements (optional)

 www.endress.com/ousaf22



3 – iTHERM CompactLine TM311

Pt100 compact thermometer, with optional integrated IO-Link and 4-20 mA transmitter, programmable via PC

- Fast installation and easy commissioning
- Excellent metrological properties thanks to innovative sensor technology
- Reliable operation ensured by approvals and certificates



www.endress.com/tm311



4 – Cerabar PMP23

Compact and cost-effective hygienic pressure transducer

- Fully welded design maximizes process safety by minimizing the use of gaskets
- IP69 ingress protection for heavy washdown conditions product
- IO-Link functionality reduces costs and complexity due to easy configuration and operation (optional)



www.endress.com/pmp23



5 – Liquiphant FTL33

Compact vibronic point level device for hygienic applications in all liquids

- Reliable function unaffected by conductivity, buildup, turbulence, foam or changing media
- Mechanically robust due to seamless sensor construction made of stainless steel and no moving parts
- Plug-and-play device, no need for calibration or adjustment



www.endress.com/ftl33



6 – Micropilot FMR62

High frequency radar for precise level measurements in liquids

- High accuracy of up to 2 mm in small and large tanks
- Unaffected by changing media properties (e.g. density, conductivity)
- Heartbeat Technology for advanced process control



www.endress.com/fmr62

Juice concentrate intake and mixing

Ensure product quality by precise mixing

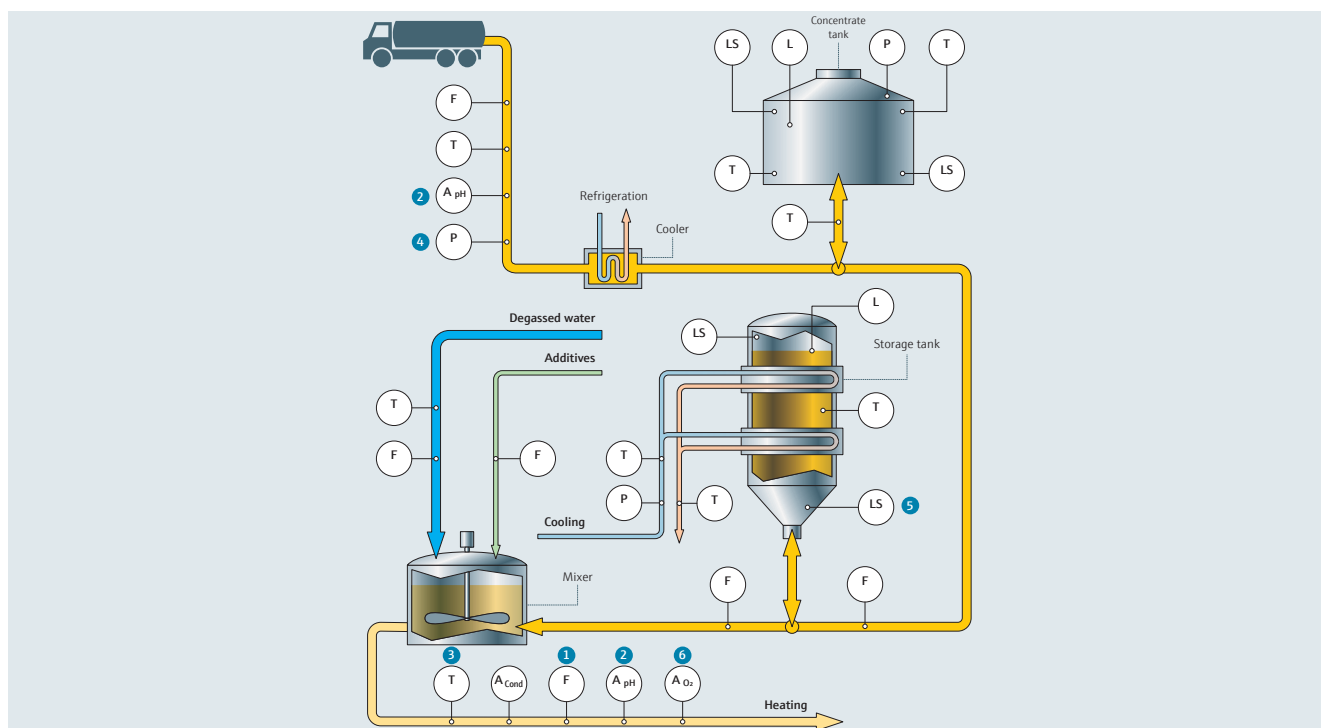

1 – Proline Promass F100

Robust Coriolis flowmeter with superior flow and density measuring accuracy

- Sophisticated functions available for high density accuracy and flexible concentration measurements
- Reliable, robust sensor: proven in hundreds of thousands of applications
- Flexible mounting: no inlet and outlet runs required



 www.endress.com/promass-f100

2 – Memosens CPS77E

pH measurement of the concentrate and the mixed juice to ensure product quality and shelf life

- Glass-free electrode, eliminating risk of glass splinters in the beverage
- Suitable for hot steam sterilization and autoclaving
- Increased process safety thanks to digital Memosens technology



 www.endress.com/cps77e



3 – iTHERM TM311

Pt100 compact thermometer, with optional integrated IO-Link and 4-20 mA transmitter, programmable via PC

- Fast installation and easy commissioning
- Excellent metrological properties thanks to innovative sensor technology
- Reliable operation ensured by approvals and certificates



www.endress.com/tm311



4 – Cerabar PMC51B

Digital pressure transmitter with oil-free ceramic sensor

- Oil free sensor technology
- Suitable for cold applications due to Contite technology
- Improved process safety due to self monitoring sensor
- Full hygienic compliance with all relevant approvals



www.endress.com/pmc51b



5 – Liquiphant FTL50H

Modular vibronic point level device for hygienic applications in all liquids

- Reliable function unaffected by conductivity, buildup, turbulence, foam or changing media
- Mechanically robust due to seamless sensor construction made of stainless steel and no moving parts
- Plug-and-play device, no need for calibration or adjustment



www.endress.com/ftl50h



6 – Memosens COS22E

Trace measurement with the Memosens COS22E digital oxygen sensor to ensure shelf life and taste

- CO₂ compatible trace sensor for the beverage industry
- High accuracy enables precise measurements resulting in superior product quality
- Low maintenance: modular sensor design enables fast exchange of membrane cap and electrolyte



www.endress.com/cos22e

How sweet is the taste of digitalization?

Digital data deliver valuable insights into the food and beverage production process. Expanding the control over the installed base means ensuring the quality of the products – and the taste.

Digitalization is the next big challenge for every industry. For the production and processing of food and beverage it is of particular relevance. The Food & Beverage industry faces the high pressure of running processes at maximum efficiency without compromising quality. In the past, there appeared to be few options in addressing this challenge. Now that the Industrial Internet of Things is unlocking data that was barely accessible before, new optimization potential is arising.

One important dimension of process optimization is intact equipment. Regardless of the type of equipment – instrumentation, pumps, valves, etc. – failures on critical tags can cause complete production downtimes in the worst case. Key equipment data can become a crucial lever for increasing reliability. At this point, it is revealing to know that 90 percent of the Endress+Hauser field devices are already digital. Their inherent intelligence can deliver relevant information once it is unlocked.

This is where Endress+Hauser's field connectivity and the Netilion IIoT ecosystem come into play. Our technology is capable of accessing crucial equipment data such as self-diagnostics or obsolescence status and instrument documentation.

Making the information and files digitally available in a safe way expands the control over the processes. Quick responses in cases of emergencies, as well as strategic operational activities, can be based on precise data and perfectly managed documents. This is how an IIoT ecosystem creates opportunities to increase plant availability.

In addition, the measurement data is more precise when accessed digitally, thus leading to greater process efficiency. Through remote monitoring for instance, inventories can be optimized so that material resources are handled ideally without risking overstocking or supply gaps. The relation between ingredients and yield can be calculated more precisely. And digital monitoring is not limited to inventory data. Automatic tracking and documentation of other measurement values, such as temperature, can ease reporting tasks.

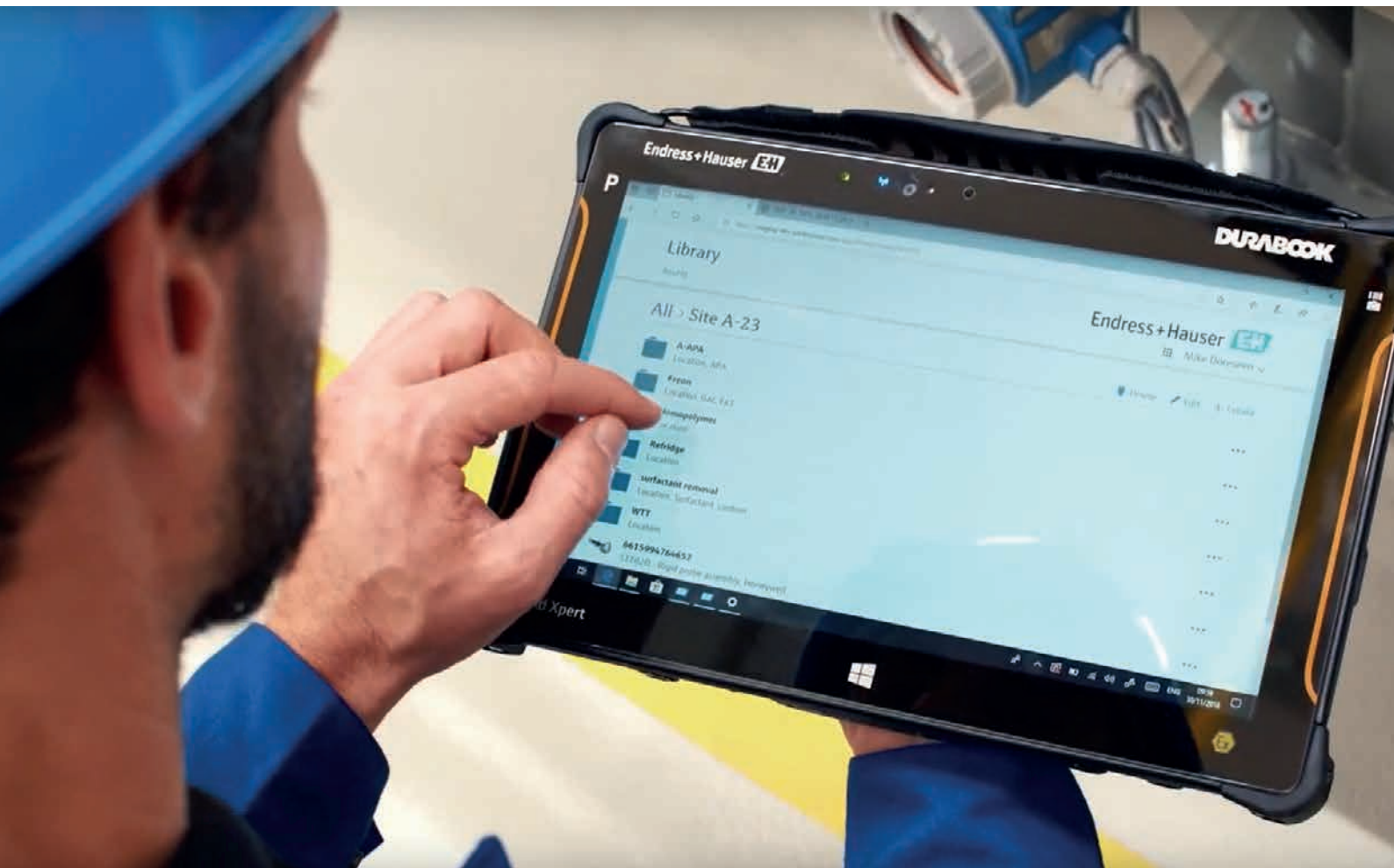

A digitalized factory opens the door to multiple optimization opportunities, even in industries that can already look back on a history of continuous improvement. Producing and processing food and beverage is not only a matter of recipes and ingredients. The entire production environment – starting with the field and ending up with documentation – plays its part in ensuring the quality and the taste of the products. And an IIoT ecosystem enables optimization of the entire facility. This is how digitalization is tied to the taste of foods and beverages.

Endress+Hauser is a trustworthy partner in implementing digital services. The development process of the products has been certified group-wide according to IEC62443-4-1. Our IIoT ecosystem Netilion fulfills the requirements of ISO 27017. Furthermore Endress+Hauser Digital Solutions complies with the ISO 27001. And Netilion is easy to implement. The standard offering comprises various digital services. The Netilion Connect API module can be utilized for individual applications. There are several ways to ensure field connectivity in order to unlock the production site data. With a partner like Endress+Hauser, whose expertise covers the hardware automation level and IIoT, you are in a position to take a major step toward the future of manufacturing.



More details on Netilion?

www.netilion.endress.com

Netilion Services

Netilion Analytics is a digital service that lets you manage all the devices in your plant. Use their data to eliminate obsolescence by optimizing and standardizing your equipment. This is the first step to keeping productivity smooth and continuous.

Netilion Health is a digital asset-health management service that puts your maintenance team a step ahead of problems. Diagnostics and cause and remedies anytime and anywhere.

Netilion Library is a file management service designed to organize documents related to your plant's instrumentation. The digital availability of these files will increase your team's performance, thanks to automated administration and simple information sharing.

Netilion Value is a digital monitoring service that connects you to your measurements wherever you are, letting you see what's happening in your facility at any time. With digital access to this information, you can manage operational quality accurately and precisely – even from a distance. And you can document your compliance.

Netilion Inventory is a digital service for inventory management that allows you to control your supplies. No matter where you are, you can monitor your containers and tanks. Having exact data about how much you have is the best way to optimize storage and logistics.

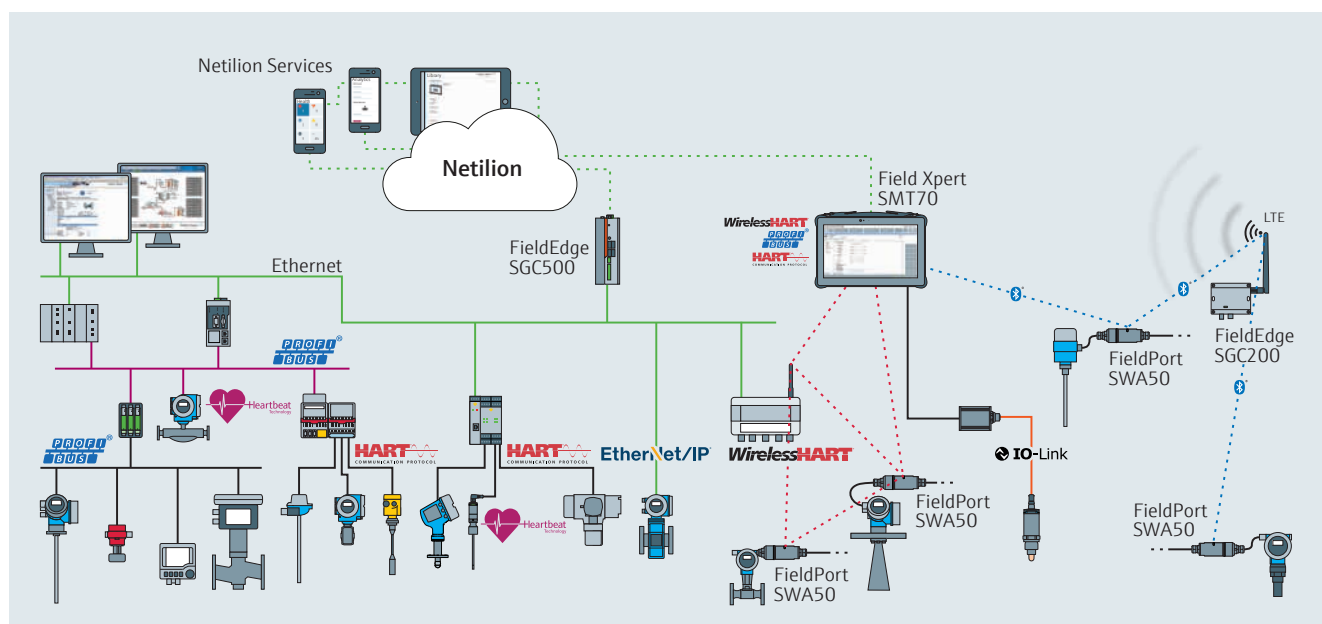

Unlock knowledge with Endress+Hauser's Netilion IIoT ecosystem

Sugar production

Innovative, robust and easy-to-clean technologies for your sugar production

Sugar production is a cost-sensitive business. Robust, durable and high-quality process instruments are of utmost importance because they increase performance and ensure constant quality. Sugar processes can be optimized without compromising product quality. Robust, easy-to-clean innovative technologies guarantee high plant availability and reduce the risk of equipment damage during maintenance.

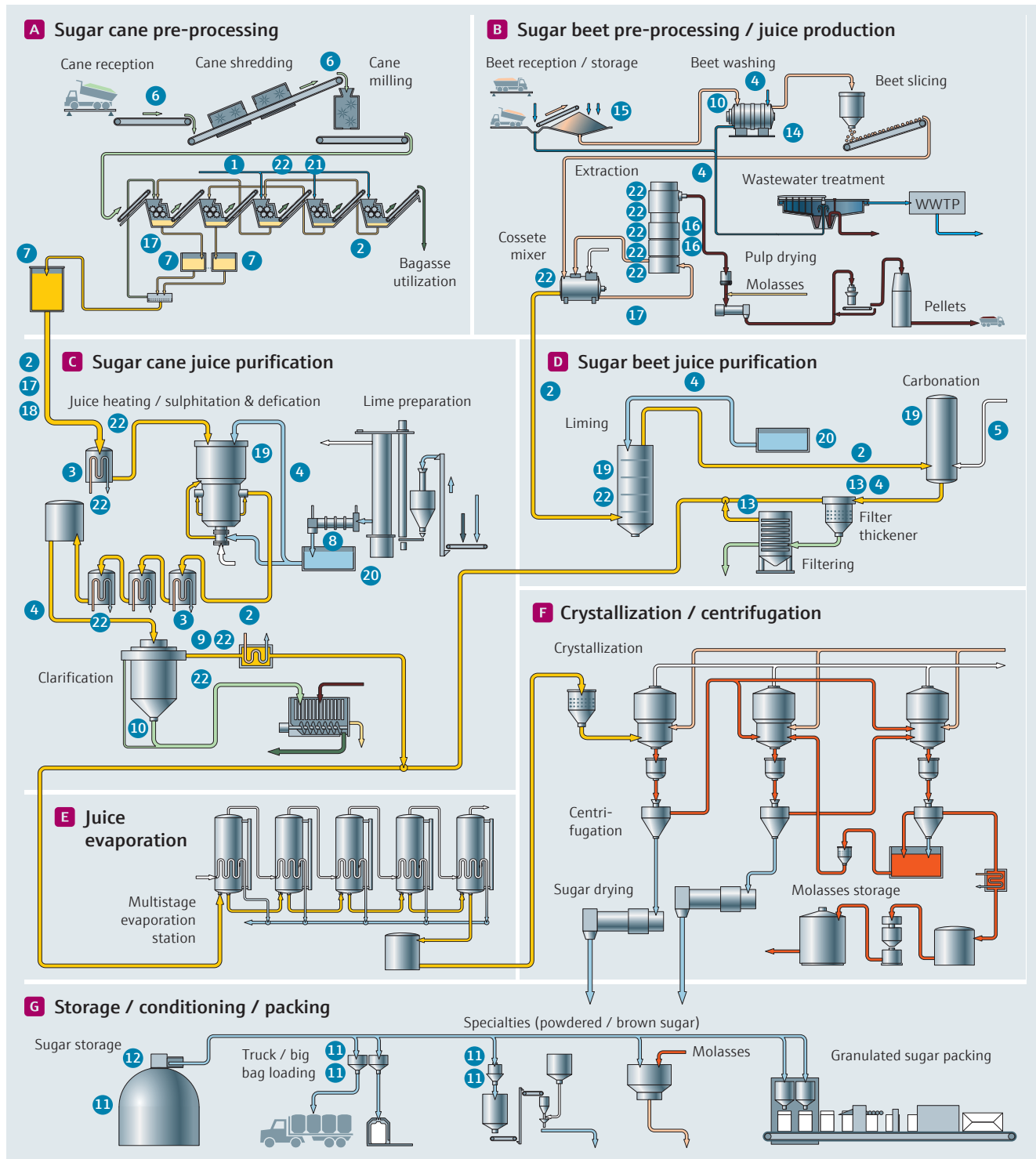

Flow

Flow in maceration water	1 Proline Promass S 100
Flow in sugar concentration mill 5 to mill 3, juice to purification, juice to liming, carbonation, sulphitation	2 Proline Promass S 300
Flow and brix threaded juice to clarification, to evaporation	3 Proline Prowirl F 200
Flow lime to reaction tank, juice to clarification tank, washing water/wastewater	4 Proline Promag 10P
Flow SO ₂ gas to reaction tank	5 Proline t-mass F 300

Level

Level reception belt, cutter	6 Micropilot FMR20
Level juice tank, raw juice tank	7 Levelflex FMP50
Level lime tank	8 Levelflex FMP51
Top level in settling tank	9 Micropilot FMR52
Level in settling tank, beet washing	10 Cerabar PMC51B
Level switch storage tank / powder mill	11 Soliphant FTM20
Level storage tank	12 Levelflex FMP57
Level switch in filtering	13 Liquiphant FTL33
Level in beet washing	14 Liquiphant FTL31
Level switch beet storage	15 Solicap FTI56
Level control in diffusion tank	16 Deltabar FMD71

Liquid analysis

pH juice first mill, raw juice before purification, before diffusion tank	17 Memosens CPS77E & Unifit CPA842
Turbidity raw juice before purification	18 Turbimax CUS52D
pH in sulphitation reaction tank	19 Memosens CPS11E & Cleanfit CPA871
pH lime solution tank	20 Memosens CPS47E & Dipfit CPA111

Pressure

Pressure in maceration water line	21 Cerabar PMP21
-----------------------------------	------------------

Temperature

Temperature in maceration water, juice heating, heat exchanger juice heating, sulphitation reaction tank, settling tank, juice heating to evaporator, liming tank, cossete mixer, diffusion tank	22 iTHERM ModuLine TM131
--	--------------------------

Evaporation

Ensure stable and reliable measurements in harsh environments

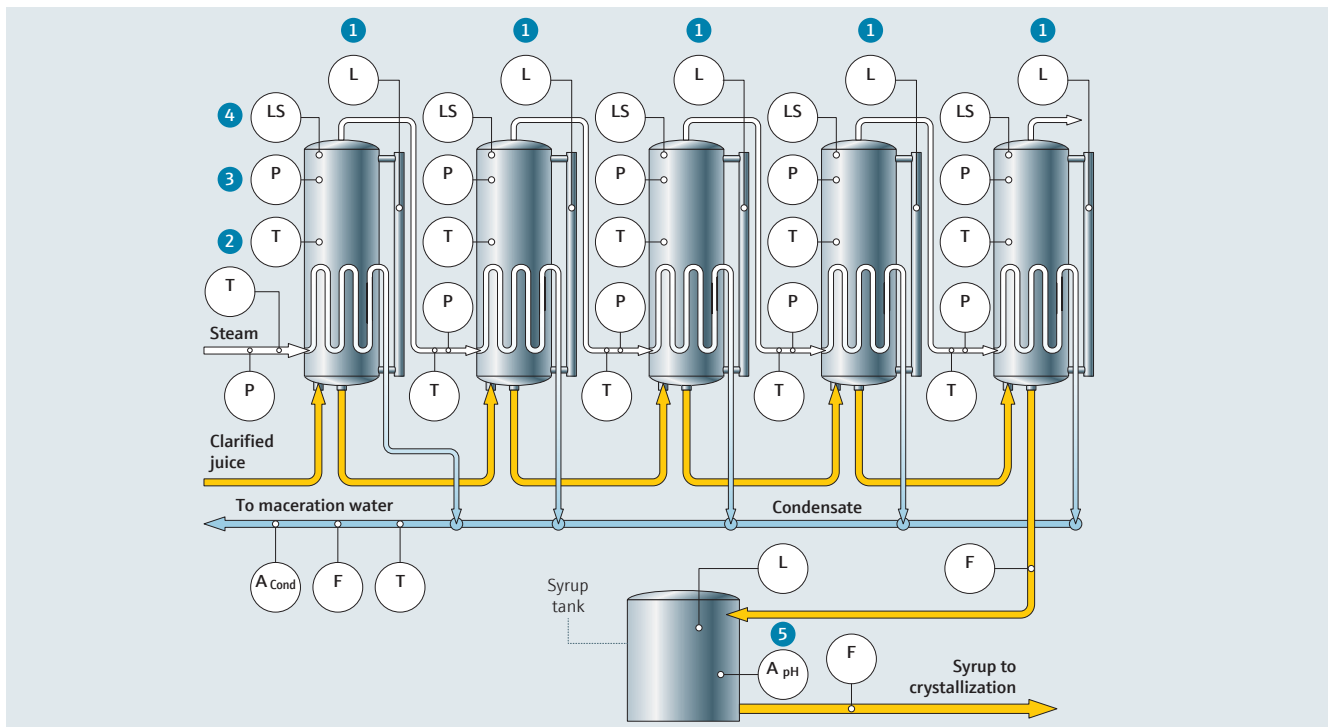

1 – Micropilot FMR62

High frequency radar for precise level measurements in liquids

- Installation in bypass possible due to small beam angle
- High accuracy of up to 2 mm in small and large tanks
- Unaffected by changing media properties (e.g. density, conductivity)
- Heartbeat Technology for advanced process control

 www.endress.com/fmr62



2 – iTHERM Moduline TM121

Thermometer with RTD or TC insert - complete with manufactured thermowell produced from pipe material

- Economical, reliable measurements
- User-friendly from product selection to maintenance
- Wide range of process connections
- Easy and safe device setup and service using Bluetooth® communication

 www.endress.com/tm121



3 – Cerabar PMC71B

Smart pressure sensor with ceramic sensor

- Heartbeat Technology for advanced process control
- Fully vacuum resistant
- Corrosion- and abrasion-resistant ceramic sensor
- High temperature resistance
- Oil free sensor technology



www.endress.com/pmc71b



4 – Liquipoint FTW33

Conductive point level device with flush-mounted hygienic design for liquid and pasty media

- Active build-up compensation
- Non-intrusive installation in pipes and tanks for easy cleaning and pigging



www.endress.com/ftw33



5 – Memosens CPS77E

pH measurements at the syrup tank after evaporation

- Glass-free ISFET sensor with bacteria-proof reference with contamination-resistant gel
- Reliable measurements to ensure highest product quality
- Unbreakable for highest product safety
- Low maintenance thanks to long calibration intervals



www.endress.com/cps77e



6 – Indumax CLS54D

Measurement of conductivity to ensure the purity of condensate in the evaporation process

- Outstanding performance combined with a unique hygienic design ensures superior safety and quality
- The sensor resists corrosion and moisture, enables lab calibration and facilitates predictive maintenance
- Suitable for cleaning-in-place (CIP) and sterilization-in-place (SIP)
- Low maintenance thanks to long calibration intervals



www.endress.com/cld54d

Crystallization

Sugar production in safe limits

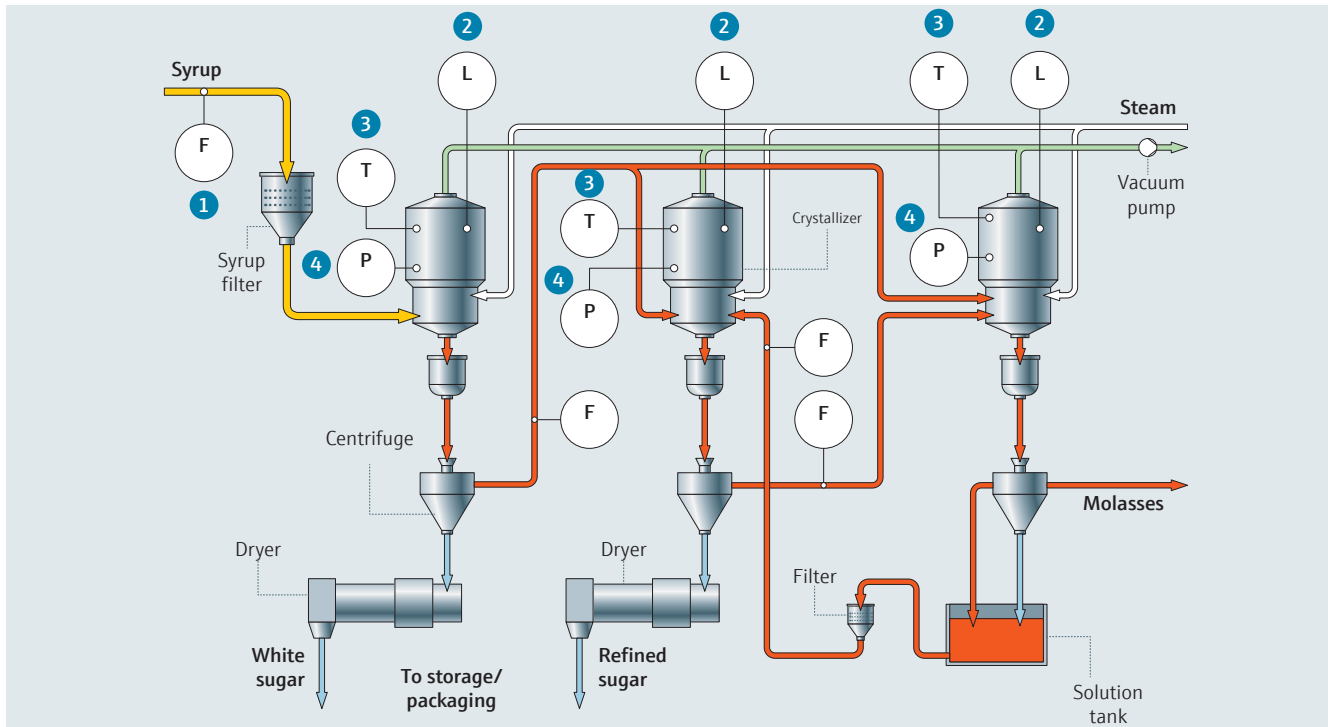

1 – Proline Promass F 300

Robust Coriolis flowmeter with superior flow and density measuring accuracy

- Reliable, robust sensor: proven in hundreds of thousands of applications
- Sophisticated functions available for high density accuracy and flexible concentration measurements
- Flexible mounting: no inlet and outlet runs required



www.endress.com/promass-f300



2 – Deltabar FMD71

Electronic differential pressure system for hydrostatic level measurements utilizing robust ceramic sensors

- Fully vacuum-resistant ceramic sensors
- Abrasion- and corrosion-resistant
- Highest precision for accurate level measurements
- Oil free sensor technology



www.endress.com/fmd71





3 – iTHERM Moduline TM121

Thermometer with RTD or TC insert - complete with manufactured thermowell produced from pipe material

- Economical, reliable measurements
- User-friendly from product selection to maintenance
- Wide range of process connections
- Easy and safe device setup and service using Bluetooth® communication



www.endress.com/tm121



4 – Cerabar PMC51B

Smart pressure transmitter with robust ceramic membrane for highly accurate measurements

- Abrasion- and corrosion-resistant sensor material
- Fully vacuum resistant
- High accuracy
- Oil free sensor technology



www.endress.com/pmc51b

Solutions

Solutions to improve productivity while lowering your costs

Endress+Hauser's food and beverage solutions not only enable the consistent quality and safety standards demanded by the industry. They deliver optimization in utilities and raw material supply and consumption. They also bring transparency in manpower and inventory management, and precision in goods transfer and distribution measurement, thus reducing the need for interaction, negotiation and weigh bridges. As a result they create efficiencies, reduce the margin for error and accelerate processes.

Stock monitoring liquids Supply chain optimization has become a key goal for companies who want to improve their position in the Food & Beverage industry. Greater transparency and collaboration between business partners is needed to develop more efficient business models such as vendor and supplier managed inventories (VMI, SMI) and custody transfer approved solutions, where high accuracy is required for weight & measure approved applications to improve the transparency of the business processes. Endress+Hauser offers integrated inventory management solutions for the transfer, storage and distribution of liquids and solids in the Food & Beverage industry.

The first priority is the safe handling of the materials, including potentially hazardous liquids such as alcohol and edible oils. Cost-effective instrumentation delivers the accuracy needed for the application. Measurement of temperature distribution improves volume and mass calculations for liquids with temperature influences, where spot temperatures are not sufficient. On-line access to information with a license-free inventory system (including weight & measure approved) is combined with remote battery-powered level measurements, all centralized in a cloud-based inventory management system to provide transparent information from sensor to board room for optimal decision making.



Liquiline Control CDC90

Minimize maintenance with automated pH measuring points

- Automatically cleans, calibrates and monitors up to 2 measurement loops
- Precise measurements and reproducible calibration results
- Seamless integration into process control systems
- Increased service lifetime
- Significantly reduced operating costs



SWAS Compact

Reliable water quality in steam circuits

- Precise measurement results even with low sample volumes
- Measure total and cation conductivity as well as pH and dissolved oxygen
- Protects boilers, turbines and heat exchangers from corrosion and deposit buildup
- Integrated pH value calculation

Drinking water monitoring panel

The reliable and compact solution for monitoring drinking water

- Monitoring of potable water
- Low water consumption for turbidity, pH and conductivity measurements
- Additional disinfection parameters such as total and free chlorine as well as chlorine dioxide or bromide



Asset Monitoring

Our Asset Health Monitoring solution is tailored to the needs of the Food & Beverage industry.

- Plant operators have the opportunity to integrate preventive maintenance into their plant upkeep procedures.
- Reliability engineering have an overview of all devices with filtering by status or searching by tag.
- Maintenance engineers have easy access to the health status of instruments in their plant, thus connecting site personnel to remote maintenance expertise in real-time.
- Instrument engineers enjoy a single device configuration management platform for all devices.

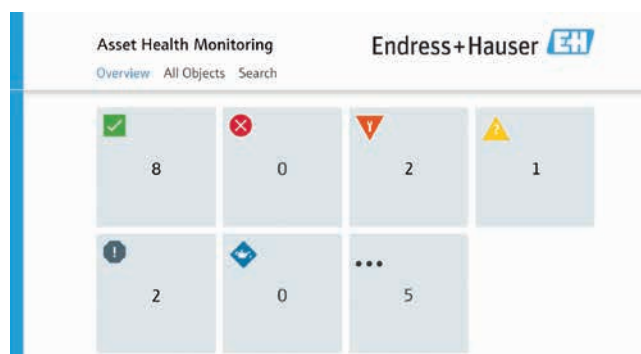

Edible oil refining

Innovative technologies ensure high production performance and plant availability

Edible oil manufacturers face the constantly growing challenges of low margins, fluctuating raw materials quality and changing consumer habits. Improving production performance and driving down operations costs calls for innovative measurement technology. Through targeted and consistent optimization of the refining process, plant operators can minimize downtime and rejects while increasing the added-value of their systems, all without sacrificing product quality.

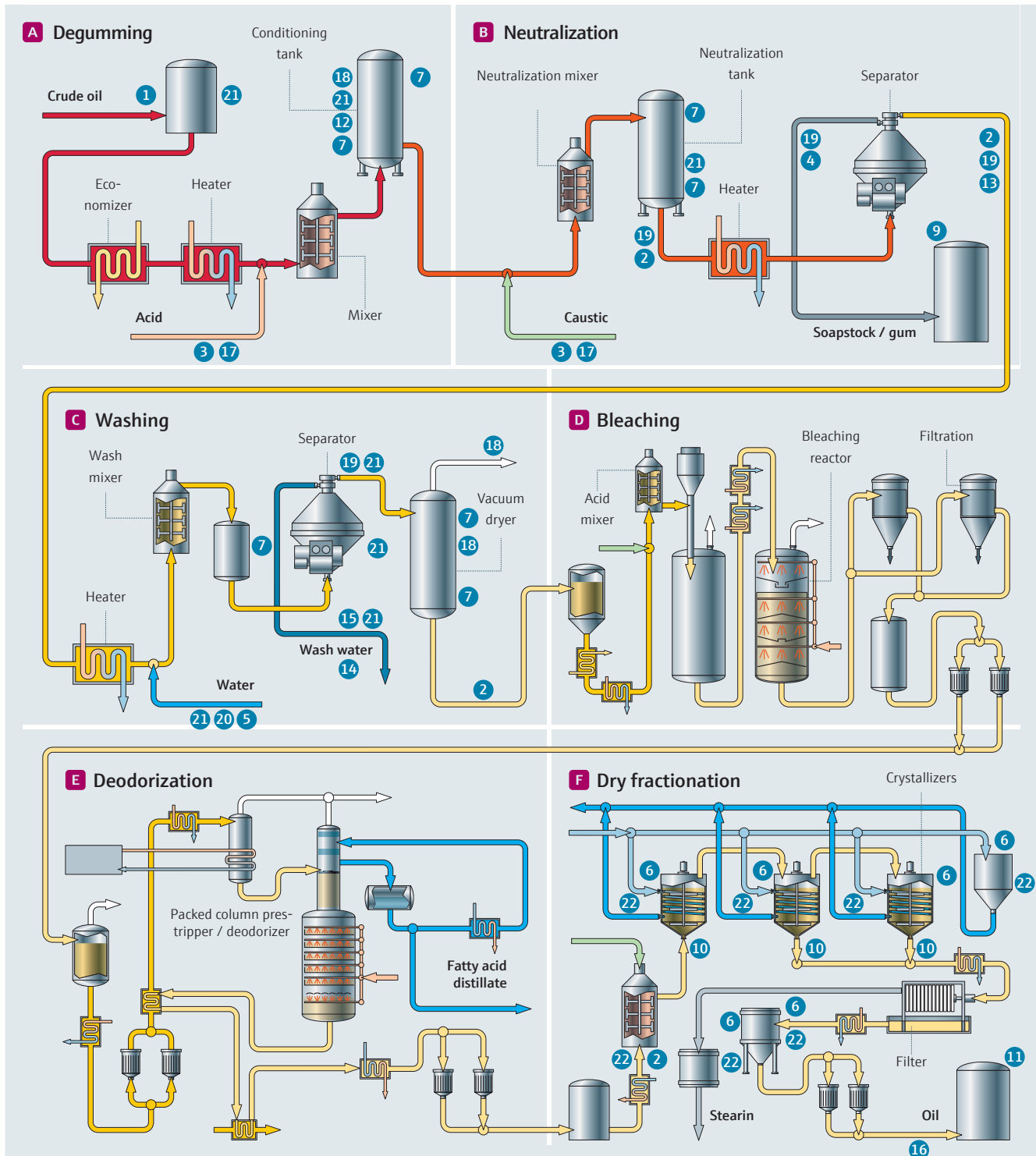

Flow

Flow crude oil reception	1 Proline Promass F 300 custody transfer
Flow crude oil, crude oil to separator, oil to wash mixer	2 Proline Promass E 100
Flow acid to crude oil mixing, caustic to neutralization	3 Proline Promag H 100
Flow gum to soapstock, to dry fractionation, to oil storage after filtration	4 Proline Promass S 100
Flow water to wash mixer	5 Proline Promag W 400

Level

Point level in crystallizer	6 Liquiphant FTL33
Point level control conditioning tank, control neutralization tank, in buffer to separator, in vacuum dryer	7 Liquiphant FTL31
Level control conditioning tank, control neutralization tank, control in vacuum dryer, in buffer to crystallizers	8 Deltabar PMD55B
Level control soapstock / gum	9 Prosonic T FMU30
Level monitoring in crystallizer	10 Deltapilot FMB50
Level control oil and stearin storage	11 Micropilot FMR52

Liquid analysis

pH control in conditioning tank	12 Memosens CPS77E
Turbidity control after separator	13 Photometer OUSTF10
pH in wash water	14 Memosens CPS11E
Conductivity in wash water	15 Smartec CLD18
Color monitoring before packaging	16 Color sensor OUSAF22

Pressure

Pressure control in acid line, control in caustic line	17 Cerabar PMP51B
Pressure in conditioning tank, in vacuum dryer	18 Cerabar PMC51B
Pressure from / to separator pipes	19 Cerabar PMC21
Pressure in water line, in filter-press	20 Cerabar PMP11

Temperature

Temperature in crude oil tank, conditioning tank, crude heating line, neutralization tank, vacuum dryer, water and wash water	21 iTHERM ModuLine TM131
Temperature after deodorization, in crystalizer	22 iTHERM TM411

Oil bleaching

Efficient removal of impurities to ensure sensor quality

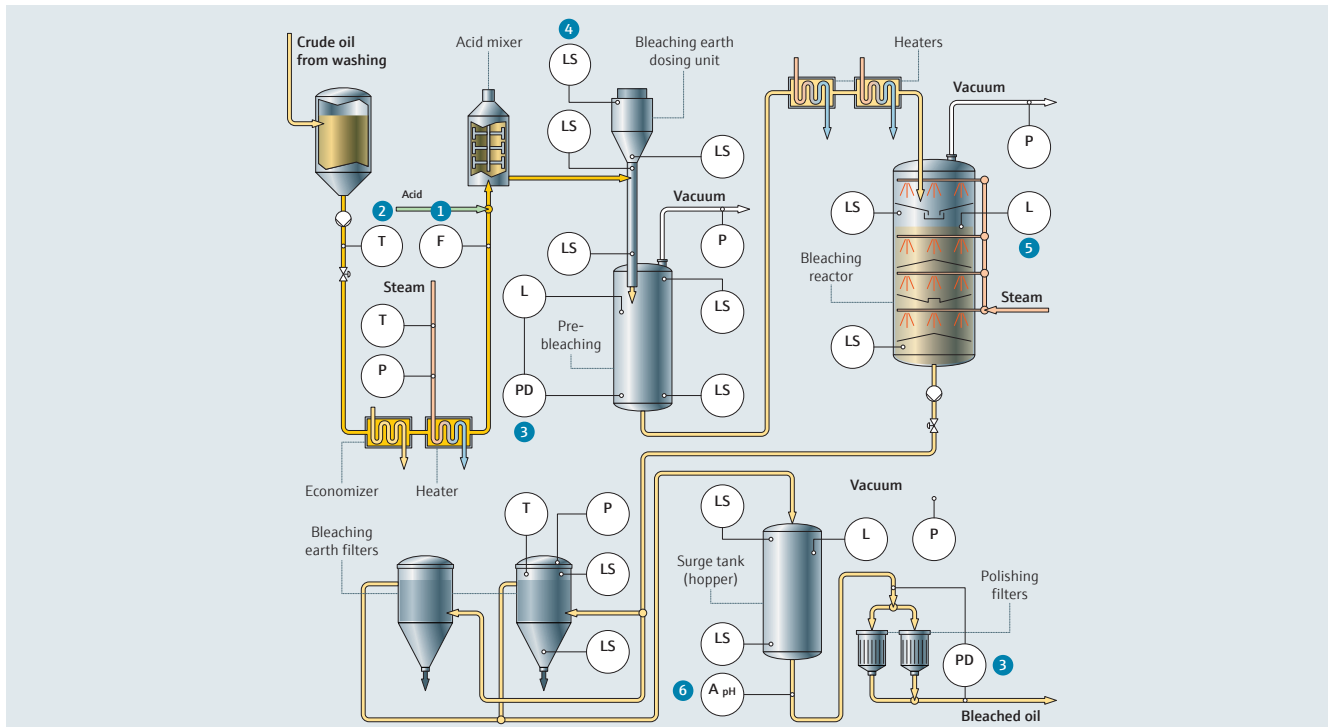

1 – Proline Promass E 100

Cost-efficient Coriolis flowmeter for non-conductive liquids in basic applications

- Robust and accurate flowmeter
- For cost-efficient operation without maintenance
- Less downtime: immediate availability after CIP/SIP cleaning
- Flexible mounting: no inlet and outlet runs required



www.endress.com/promass-e100



2 – iTHERM ModuLine TM101

RTD or thermocouple temperature probe for direct installation in various industrial applications

- Excellent price/performance ratio and fast global delivery
- User-friendly product selection, smart design for easy maintenance
- Wide range of process connections
- Bluetooth® connectivity (optional)



www.endress.com/tm101



3 – Deltabar FMD71

Electronic differential pressure system utilizing two robust ceramic sensor modules

- Superior precision for accurate filter monitoring
- Abrasion- and corrosion-resistant ceramic sensors
- Fully vacuum resistant



www.endress.com/fmd71



4 – Liquiphant FTL51B

Smart vibronic switch for point level measurements in all kinds of liquids

- Reliable function unaffected by conductivity, buildup, turbulence, foam or changing media
- Mechanically robust due to seamless stainless steel design with no moving parts
- Plug-and-play device, no need for calibration or adjustment
- Heartbeat Technology for improved process safety and predictive maintenance



www.endress.com/ftl51b



5 – Micropilot FMR62

High frequency radar for precise level measurements in liquids

- High accuracy of up to 2mm in small and large tanks
- Unaffected by changing media properties (e.g. density, conductivity)
- Heartbeat Technology for advanced process control



www.endress.com/fmr62



6 – Memosens CPS77E

Reliable pH measurements after the surge tank

- Precise performance even at high organic and low water content
- Unbreakable glass-free ISFET sensor for product quality, safety and reliability
- Low maintenance even in harsh and humid environment thanks to long calibration intervals



www.endress.com/cps77e

Oil deodorization

Ensure highest quality and maintain oil characteristics

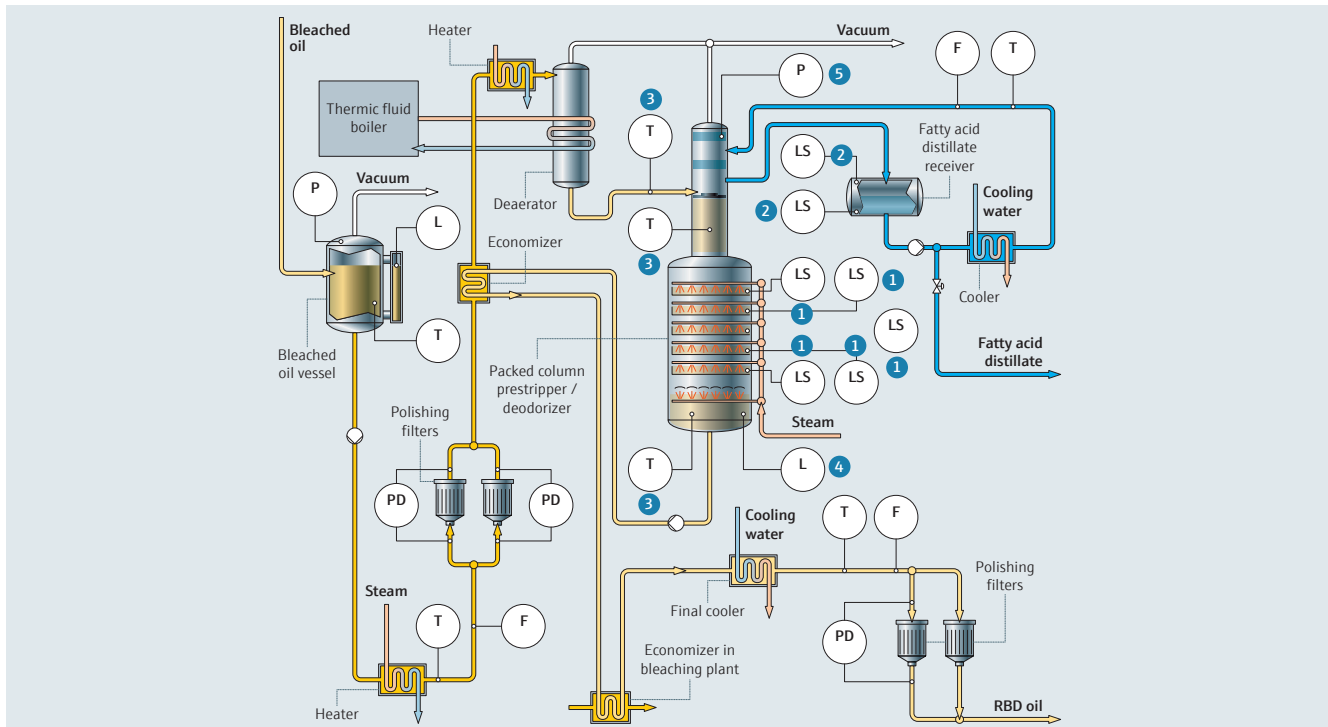

1 – Liquiphant FTL41

The modular and universal vibronic level switch reduces complexity in your plant

- Reliable function unaffected by conductivity, buildup, turbulence, foam or changing media
- Mechanically robust due to seamless sensor construction made of stainless steel with no moving parts
- Plug-and-play device, no need for calibration or adjustment
- Proven, reliable vibration fork technology



www.endress.com/ftl41



2 – Liquiphant FTL31

Cost-effective point level switch

- Compact design
- Universal application fit
- Seamless sensor construction
- Plug-and-play device, no need for calibration or adjustment
- Proven, reliable vibration fork technology



www.endress.com/ftl31





3 – iTHERM ModuLine TM101

RTD or thermocouple temperature probe for direct installation in various industrial applications

- Excellent price/performance ratio and fast global delivery
- User-friendly product selection, smart design for easy maintenance
- Wide range of process connections
- Bluetooth® connectivity (optional)



www.endress.com/tm101



4 – Deltapilot FMB50

Compact pressure sensor with the Contite measuring cell for hydrostatic level measurements

- Hermetically sealed Contite measuring cell with full condensate-resistance and minimum temperature effects
- High reference accuracy for precise hydrostatic level measurements
- Seamless and independent system integration with HART, IO-Link, Profibus, etc.



www.endress.com/fmb50



5 – Cerabar PMC51B

Smart pressure transmitter with robust ceramic membrane for highly accurate measurements

- Abrasion- and corrosion-resistant sensor material
- Fully vacuum resistant
- Superior accuracy
- Oil free sensor technology



www.endress.com/pmc51b

Cleaning in Place – CIP process

Reduce cleaning time, energy and detergents

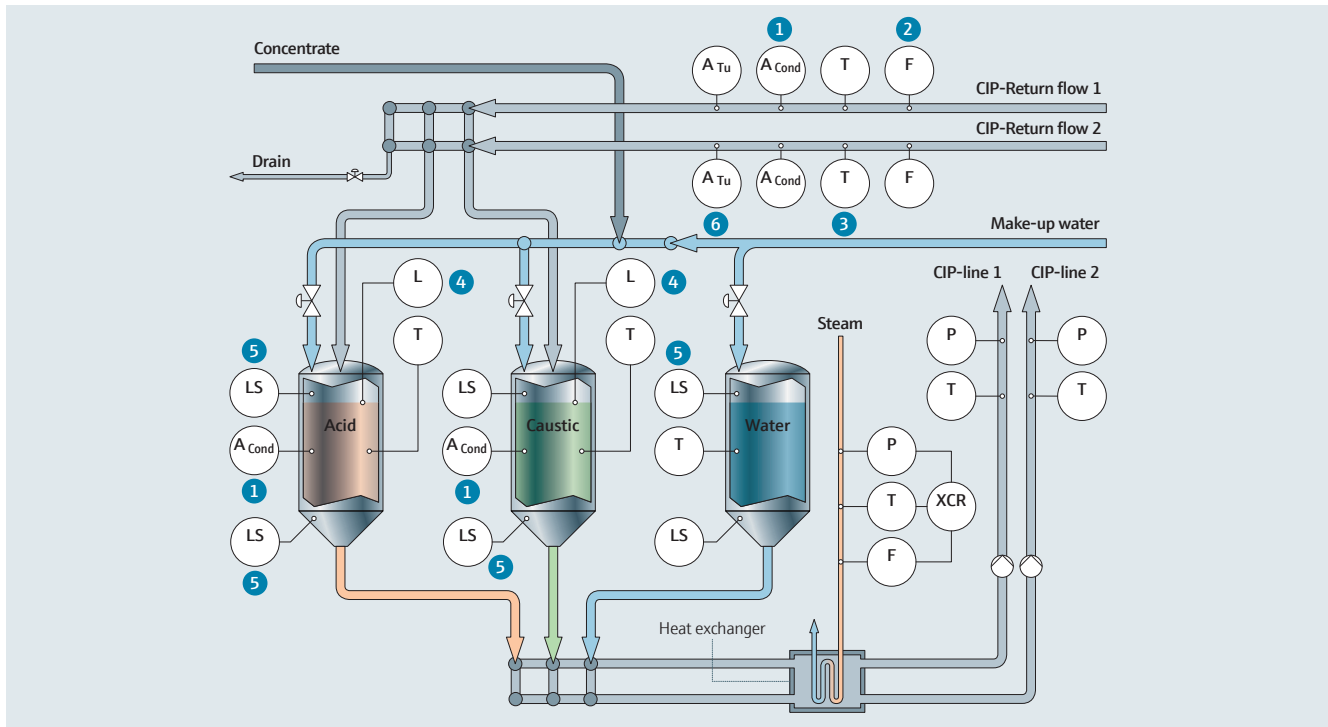

1 – Indumax CLS54D

Concentration measurements in CIP return flow and buffer tanks

- Precise and temperature-compensated conductivity measurements
- Unique hygienic design prevents contamination
- Cost reduction through the economical dosing of cleaning detergents
- Reliable values thanks to active connection monitoring and EMC protection



www.endress.com/cls54d



2 – Promag H 10

Cost-efficient flowmeter for basic hygienic applications with easy-to-use operations concept

- Fewer measuring points thanks to multivariable volume flow, temperature and conductivity measurements
- Easy operation via mobile devices (Bluetooth®) and SmartBlue app, or via touch screen
- Energy-saving measurements – no pressure loss due to full-bore design



www.endress.com/promag-h10





3 – iTHERM TM411

Innovative and advanced modular RTD thermometer

- iTHERM QuickSens: fastest response times ($t_{90} = 1.5 \text{ s}$) for optimal process control
- iTHERM QuickNeck – cost and time savings thanks to simple, tool-free recalibration



www.endress.com/tm411



4 – Deltapilot FMB50

Compact pressure sensor with the Contite measuring cell for hydrostatic level measurements

- Hermetically sealed Contite measuring cell with full condensate-resistance and minimum temperature effects
- Superior reference accuracy for precise hydrostatic level measurements
- Seamless and independent system integration with HART, IO-Link, Profibus, etc.



www.endress.com/fmb50



5 – Liquiphant FTL51B

Smart vibronic device for point level measurements in all kinds of liquids

- Reliable function unaffected by conductivity, buildup, turbulence, foam or changing media
- Mechanically robust due to seamless stainless steel design with no moving parts
- Plug-and-play device, no need for calibration or adjustment
- Heartbeat Technology for improved process safety and predictive maintenance



www.endress.com/ftl51b



6 – Glass-free absorption sensor OUSAF11

Optical turbidity measurements in CIP return flow for product loss detection in effluent

- High product safety thanks to glass-free, hygienic design
- Cost savings and reduced product loss thanks to fast interphase detection
- Easy installation with with Triclamp and Varivent connectors



www.endress.com/ousaf11

Customer insights

Endress+Hauser has been working closely with its customers in the Food & Beverage industry for more than 60 years. Here are some of their thoughts on our performance.



"With the FieldXpert I have simple and fast mobile access to the current energy utilization data from anywhere, plus I can analyze trends and configure the instruments. Combined with the Memograph, we can exploit the advantages of digitalization down to the field instrument level."



MÜNCHEN

Silvio Di Tano
Head of Electronics
Staatliches Hofbräuhaus München

"We rely on the expertise of Endress+Hauser. And the best thing is, this leaves us more time to focus on our own core expertise: producing regional, high-quality dairy products."



Meinhard Schuler
Head of production
Milchwerke Schwaben eG

"With Endress+Hauser we have chosen a partner with worldclass support and a full-range supplier with a very good reputation."



Dr. Ralph Schneid
Breweries Product Management
Krones AG, Steinecker plant

"The Picomag flowmeter from Endress+Hauser completely met our expectations with respect to functionality, performance and engineering design."



Daniel Frommel
Head of Engineering Projects,
Ehrmann AG



Improvements in edible oils refining

C. Thywissen GmbH relies on process control technology from Endress+Hauser

C. Thywissen GmbH, headquartered in Neuss, Germany, processes 2,000 tons of plant seeds daily. One of the essential prerequisites is the reliable monitoring, regulation and control of each individual step in the process that leads to edible vegetable oil. Ensuring consistent product quality and the optimal use of resources is the highest priority. Robust instruments from Endress+Hauser reliably perform their respective measurement task along the entire production process, from delivery of the raw materials to refining.

“Endress+Hauser is a competent partner. We are constantly persuaded by the extensive and reliable product portfolio and the quick response whenever we need support.”



Daniel Sengpiel
Head of Electronics Engineering,
C. Thywissen GmbH, Neuss, Germany



Instrumentation for a progressive dairy company project

MILEI relies on measurement technology from Endress+Hauser

MILEI 2.0 refers to the new plant in Leutkirch that boasts an additional 15,600 square meters of production space, where the highest quality products are manufactured with maximum efficiency. In this large scale project, Endress+Hauser is responsible for the instrumentation that is used for both standard and more-demanding hygiene applications.

“Standardizing the equipment of our new systems involves a tremendous amount of effort. For this reason, we decided to place the responsibility for the measurement technology completely in the hands of Endress+Hauser. This allowed us to significantly reduce the internal storage and training effort.”



Gert Henke
Head of Engineering,
MILEI GmbH, Leutkirch



...and how can we help you to improve your process? Visit us at:
www.endress.com/food-beverage

www.endress.com

S001090B/60/EN/01.2021